

D3-110I-B, D3-130A-B, D3-130I-B, D3-160A-B, D3-160I-B, D3-190A-B, D3-190I-B

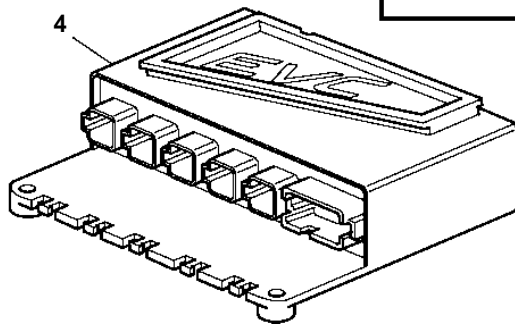
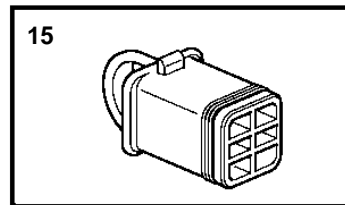
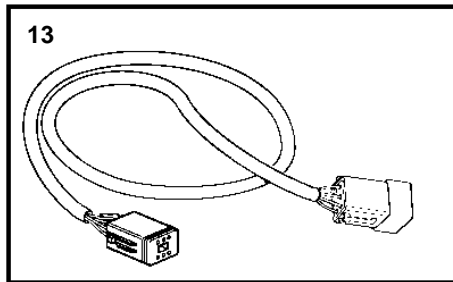
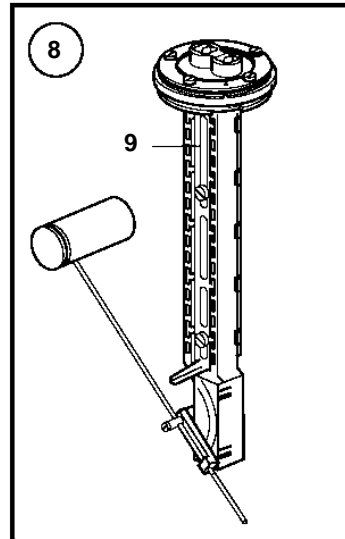
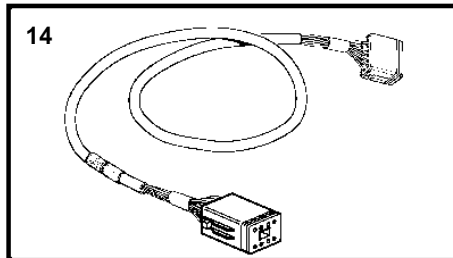
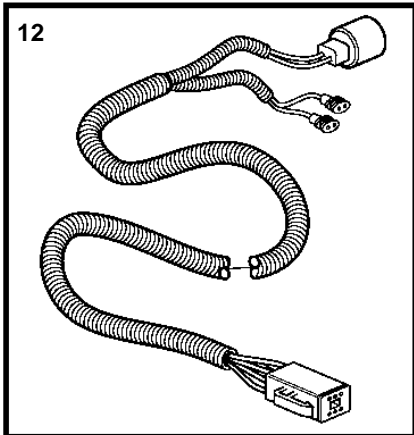
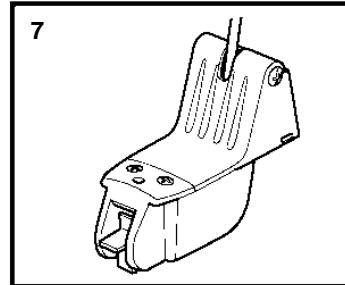
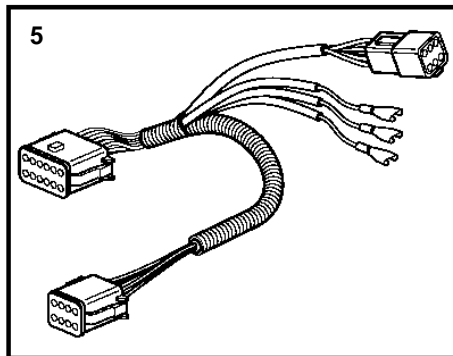
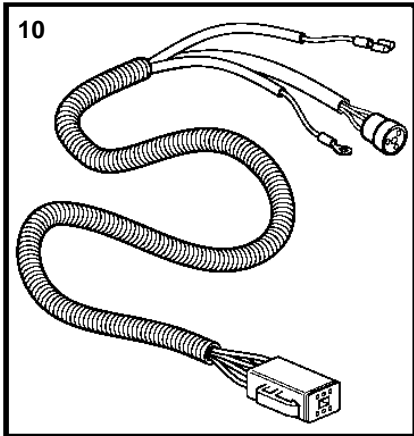
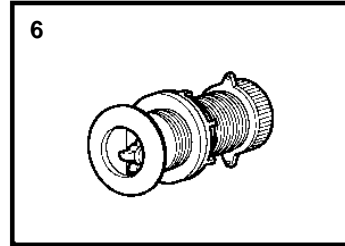
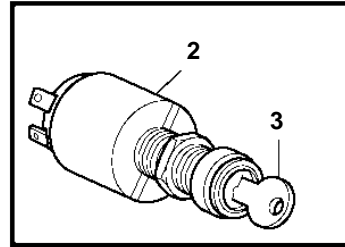
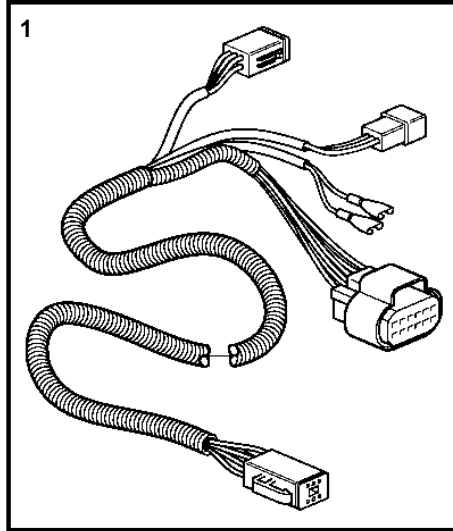
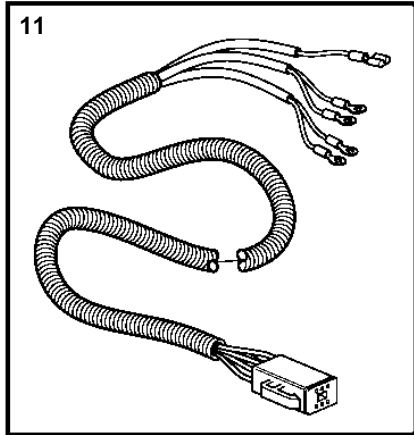

22917

D3-110I-B, D3-130A-B, D3-130I-B, D3-160A-B, D3-160I-B, D3-190A-B, D3-190I-B

REF	PART NO.	QTY	DESCRIPTION	SEE SEC.	NOTES
1	881801	1	Wiring harness		Included in EVC cable kit 3587052., L=2,0m
2	3587071	1	Starter switch		
3	859953	1	· Key		State key code when ordering.
			· Bulletin 49-30	49-30-EN	Key P/N 859953
4	21252272	1	Module		HIU for reverse gear
	21252275	1	Module		HIU for SX drive
	3589927	1	Software		Warehouse programming. This p/n can not be ordered, but will be used for invoicing.
	3589926	1	Software		Vodia-programming. This p/n can not be ordered, but will be used for invoicing.
5	21207240	1	Wiring harness		ECU to Engine
6	3587054	1	Kit		
7	3587055	1	Kit		
8	874840	1	Sensor		
9	873772	1	· Tank sensor		
10	3807228	1	Wiring harness		For Trim instrument and Instrument light, L=0.5m
11	3807229	1	Wiring harness		For fuel level sender, L=5.0m
12	881804	1	Wiring harness		For trim pump and trim sender, Included in EVC cable kit 3587052., L=5.0m
13	3842733	1	Extension cable\verl		L=3.0m, 6-Way
	3842734	1	Extension cable\verl		L=5.0m, 6-Way
	3842735	1	Extension cable\verl		L=7.0m, 6-Way
	3842736	1	Extension cable\verl		L=9.0m, 6-Way
	3842737	1	Extension cable\verl		L=11.0m, 6-Way
14	888248	1	Extension cable\verl		Multilink., L=10.0' (3.0m), 8-way.
	888249	1	Extension cable\verl		L=5.0m, 8-way.
	888250	1	Extension cable\verl		L=23.0' (7.0m), 8-way.
	888251	1	Extension cable\verl		L=9.0m, 8-way.
	888253	1	Extension cable\verl		L=11,00m, 8-way.
15	3840433	1	Sealing plug		Plug for connection in HIU when reverse gear is used.