

D3-110I-A, D3-110I-B, D3-110I-C, D3-130A-A, D3-130I-A, D3-130A-B, D3-130I-B, D3-130A-C, D3-130I-C, D3-160A-A, D3-160I-A, D3-160A-B, D3-160I-B, D3-160A-C, D3-160I-C, D3-190A-B, D3-190I-B, D3-190A-C, D3-190I-C

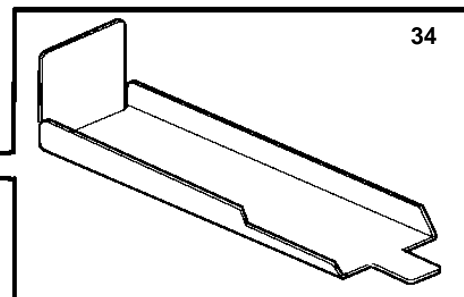
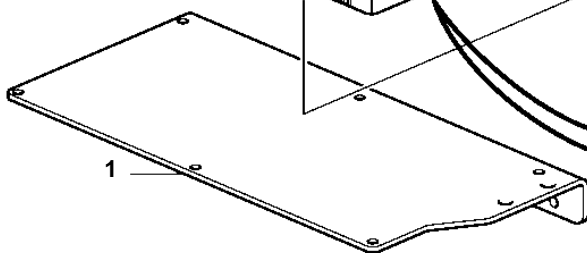
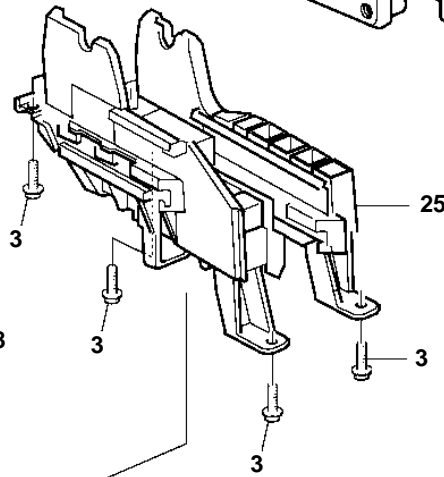
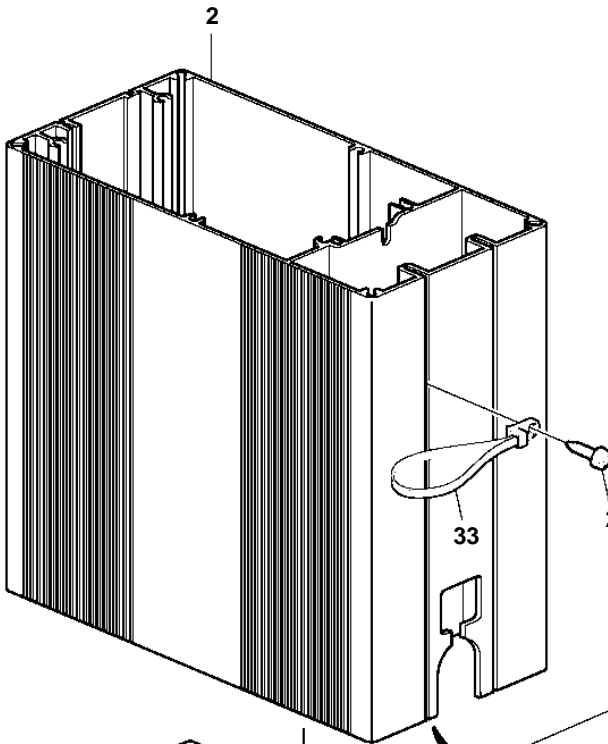
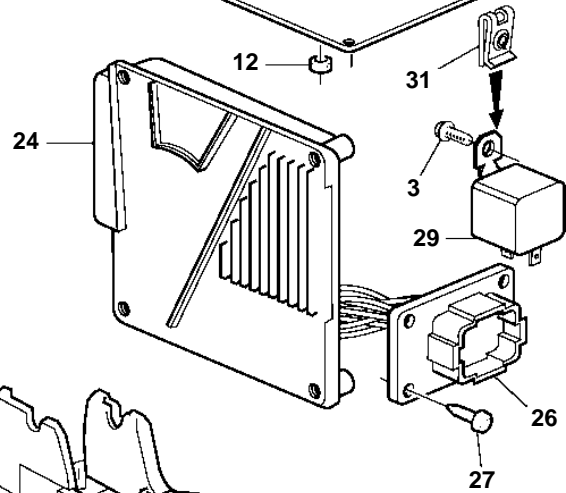
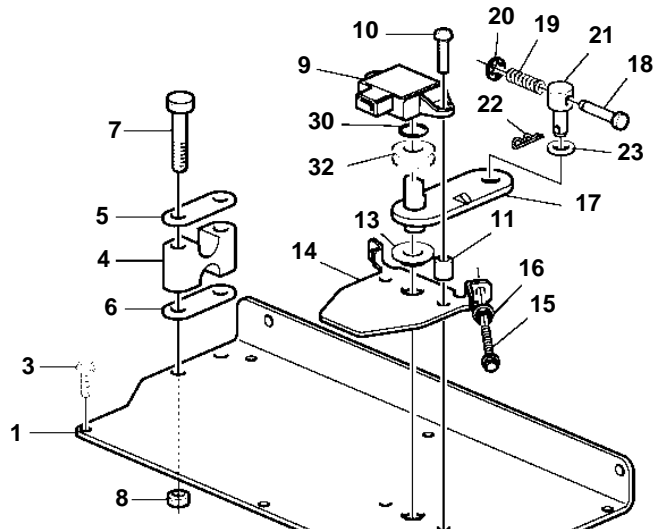
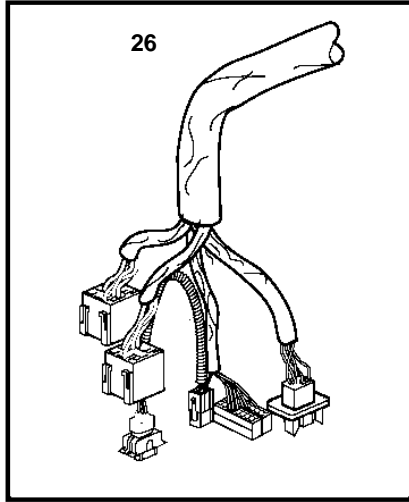

20467

Upd: 2009-12-14

20467

7744550 - 30 - 6741

D3-110I-A, D3-110I-B, D3-110I-C, D3-130A-A, D3-130I-A, D3-130A-B, D3-130I-B, D3-130A-C, D3-130I-C, D3-160A-A, D3-160I-A, D3-160A-B, D3-160I-B, D3-160A-C, D3-160I-C, D3-190A-B, D3-190I-B, D3-190A-C, D3-190I-C

REF	PART NO.	QTY	DESCRIPTION	NOTES
1	3807834	2	Cardboard tube	
2	3807556	1	Box frame	
3	947493	17	Flange screw	
4	872074	1	Retainer	
5	819068	1	Washer	
6	872076	1	Washer	
7	969439	2	6 point socket screw	
8	949874	2	Flange lock nut	
9	1336385	1	Potentiometer	
10	969558	2	6 point socket screw	
11	3825525	2	Spacer sleeve	
12	963103	2	Lock nut	
13	3829680	1	Bushing	
14	3807844	1	Bracket	
15	947542	2	Flange screw	
16	945407	2	Flange nut	
17	3825366	1	Intermediate lever	
18	814083	1	Adjusting nut	
19	814086	1	Spring	
20	968766	1	Retainer	
21	814085	1	Cube	
22	664822	1	Split pin	
23	955893	1	Washer	
24	3586930	1	Control unit	
	3586269		Software	Warehouse programming. This p/n can not be ordered, but will be used for invoicing.
	3586268		Software	Vodia-programming. This p/n can not be ordered, but will be used for invoicing.
25	3807843	1	Bracket	
26	3807365	1	Cable kit	
27	969456	4	6 point socket screw	
28	969456	1	6 point socket screw	
29	873740	2	Relay	
30	943342	1	Sealing ring	
31	191391	2	Spring nut	
32	3829681	1	Washer	
33	949666	1	Cable tie	
34	21253185	1	Insulating cover	