

D3-110I-C, D3-130A-C, D3-130I-C, D3-160A-C, D3-160I-C, D3-190A-C, D3-190I-C

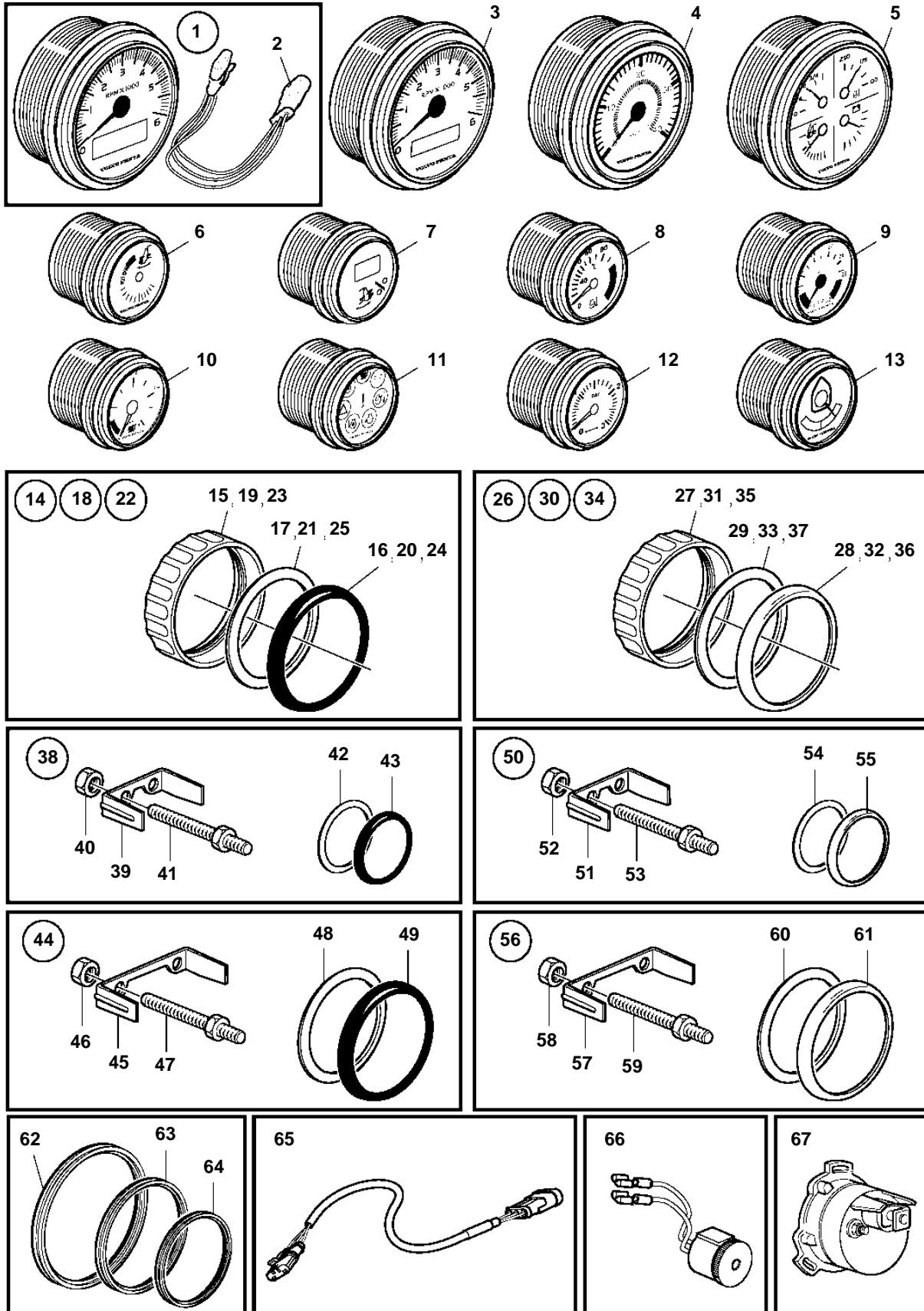

23769

D3-110I-C, D3-130A-C, D3-130I-C, D3-160A-C, D3-160I-C, D3-190A-C, D3-190I-C

REF	PART NO.	QTY	DESCRIPTION	SEE SEC.	NOTES
1	3847841	1	Tachometer kit		BLACK, D=110mm, Only for main helm station, Cable not included
			• Bulletin P-36-9-3	P-36-9-3-EN	New products in the EVC family
1	3847844	1	Tachometer kit		WHITE, D=110mm, Only for main helm station, Cable not included
			• Bulletin P-36-9-3	P-36-9-3-EN	New products in the EVC family
1	3885696	1	Tachometer		BLACK, D=85mm, Only for main helm station, Cable included
	3885697	1	Tachometer		WHITE D=85mm, Only for main helm station, Cable included
2	3884843	1	• Wiring harness		
3	881647	1	Tachometer		Engine speed/hours, Black D=85mm, Only for secondary helm station
	881653	1	Tachometer		Engine speed/hours, WHITE D=85mm, Only for secondary helm station
	3586222	1	Kit		Engine speed/hours, text messages, Black D=85mm, Only for secondary helm station
	3586223	1	Kit		Engine speed/hours, text messages, WHITE D=85mm, Only for secondary helm station
4	874916	1	Speedometer		BLACK 0-20 Knots
	874917	1	Speedometer		Black 0-40 Knots
	881645	1	Speedometer		Black 0-60 Knots
	874929	1	Speedometer		WHITE 0-20 Knots
	874930	1	Speedometer		White 0-40 Knots
	881650	1	Speedometer		White 0-60 Knots
	3847867	1	Speedometer		Unit neutral, WHITE, D=110mm, 0-40
			• Bulletin P-36-9-3	P-36-9-3-EN	New products in the EVC family
4	3847864	1	Speedometer		Unit neutral, BLACK, D=110mm, 0-40
			• Bulletin P-36-9-3	P-36-9-3-EN	New products in the EVC family
4	3847873	1	Speedometer		Unit neutral, WHITE, D=110mm, 0-60
			• Bulletin P-36-9-3	P-36-9-3-EN	New products in the EVC family
4	3847870	1	Speedometer		Unit neutral, BLACK, D=110mm, 0-60
			• Bulletin P-36-9-3	P-36-9-3-EN	New products in the EVC family
5	3885214	1	Instrument		Four in one gauge (oil pressure, coolant temp, fuel level, volt meter), WHITE
			• Bulletin P-36-9-3	P-36-9-3-EN	New products in the EVC family
5	3885215	1	Instrument		Four in one gauge (trim analog, coolant temp, fuel level, volt meter), WHITE
			• Bulletin P-36-9-3	P-36-9-3-EN	New products in the EVC family
5	3847876	1	Instrument		Four in one gauge (oil pressure, coolant temp, fuel level, volt meter), D=110mm, BLACK
			• Bulletin P-36-9-3	P-36-9-3-EN	New products in the EVC family
5	3847879	1	Instrument		Four in one gauge (trim analog, coolant temp, fuel level, volt meter), D=110mm, BLACK
			• Bulletin P-36-9-3	P-36-9-3-EN	New products in the EVC family
6	3812881	1	Instrument		Black analog
	3812911	1	Instrument		White analog
7	881648	1	Trimmer		Black digital
	881654	1	Trimmer		White digital
8	874904	1	Thermometer, coolant water		Black 0-120°C
	874921	1	Thermometer, coolant water		White 0-120°C
	874918	1	Thermometer, coolant water		Black 40-250 °F
	874931	1	Thermometer, coolant water		White 40-250 °F
9	881649	1	Voltmeter		Black
	881658	1	Voltmeter		WHITE
10	874914	1	Fuel gauge		Black D=52mm
	874926	1	Fuel gauge		White D=52mm
11	874915	1	Instrument, alarm		Black D=52mm
	874927	1	Instrument, alarm		White D=52mm
12	874910	1	Turbo pressure gauge		Black 0-3 bar
	874920	1	Turbo pressure gauge		BLACK 0-45 PSI
	874924	1	Turbo pressure gauge		WHITE 0-3 bar
	874933	1	Turbo pressure gauge		WHITE 0-45 PSI
13	3812914	1	Rudder indicator		BLACK
	3812917	1	Rudder indicator		WHITE

D3-110I-C, D3-130A-C, D3-130I-C, D3-160A-C, D3-160I-C, D3-190A-C, D3-190I-C

REF	PART NO.	QTY	DESCRIPTION	SEE SEC.	NOTES
14	874709	1	Mounting kit		Black D=52mm
15	874450	1	• Attaching ring		
16	874448	1	• Ring		
17	874707	1	• Gasket		
18	874708	1	Mounting kit		Black D=85mm
19	874449	1	• Attaching ring		
20	874447	1	• Ring		
21	874706	1	• Gasket		
22	3847888	1	Mounting kit		BLACK D=110mm
			• Bulletin P-36-9-3	P-36-9-3-EN	New products in the EVC family
23	3884098	1	• Attaching ring		
24	3847887	1	• Ring		
25	3884103	1	• Gasket		
26	874733	1	Mounting kit		Chrome D=52mm
27	874450	1	• Attaching ring		
28	874731	1	• Ring		
29	874707	1	• Gasket		
30	874732	1	Mounting kit		Chrome D=85mm
31	874449	1	• Attaching ring		
32	874730	1	• Ring		
33	874706	1	• Gasket		
34	3885216	1	Mounting kit		CHROME D=110mm
			• Bulletin P-36-9-3	P-36-9-3-EN	New products in the EVC family
35	3884098	1	• Attaching ring		
36	3884096	1	• Ring		
37	3884103	1	• Gasket		
38	881611	1	Brace kit		Black D=52mm
39	881607	1	• Brace		
40	881610	2	• Nut		
41	881609	2	• Stud		
42	874707	1	• Gasket		
43	874448	1	• Ring		
44	881612	1	Brace kit		Black D=85mm
45	881608	1	• Brace		
46	881610	2	• Nut		
47	881609	2	• Stud		
48	874706	1	• Gasket		
49	874447	1	• Ring		
50	881613	1	Brace kit		Chrome D=52mm
51	881607	1	• Brace		
52	881610	2	• Nut		
53	881609	2	• Stud		
54	874707	1	• Gasket		
55	874731	1	• Ring		
56	881614	1	Brace kit		Chrome D=85mm
57	881608	1	• Brace		
58	881610	2	• Nut		
59	881609	2	• Stud		
60	874706	1	• Gasket		
61	874730	1	• Ring		
62	3886791	1	X-ring		For flush mounting., D=110mm
			• Bulletin P-36-9-3	P-36-9-3-EN	New products in the EVC family
63	874844	1	X-ring		For flush mounting., D=85mm
64	874843	1	X-ring		For flush mounting., D=52mm
65	874759	1	Extension cable\verl		L=1000mm
	3807043	1	Extension cable\verl		L=3000mm
66	3817974	1	Alarm		
67	3809099	1	Sensor		Rudder indicator