

D3-110I-A, D3-110I-B, D3-110I-C, D3-130A-A, D3-130I-A, D3-130A-B, D3-130I-B, D3-130A-C, D3-130I-C, D3-160A-A, D3-160I-A, D3-160A-B, D3-160I-B, D3-160A-C, D3-160I-C, D3-190A-B, D3-190I-B, D3-190A-C, D3-190I-C

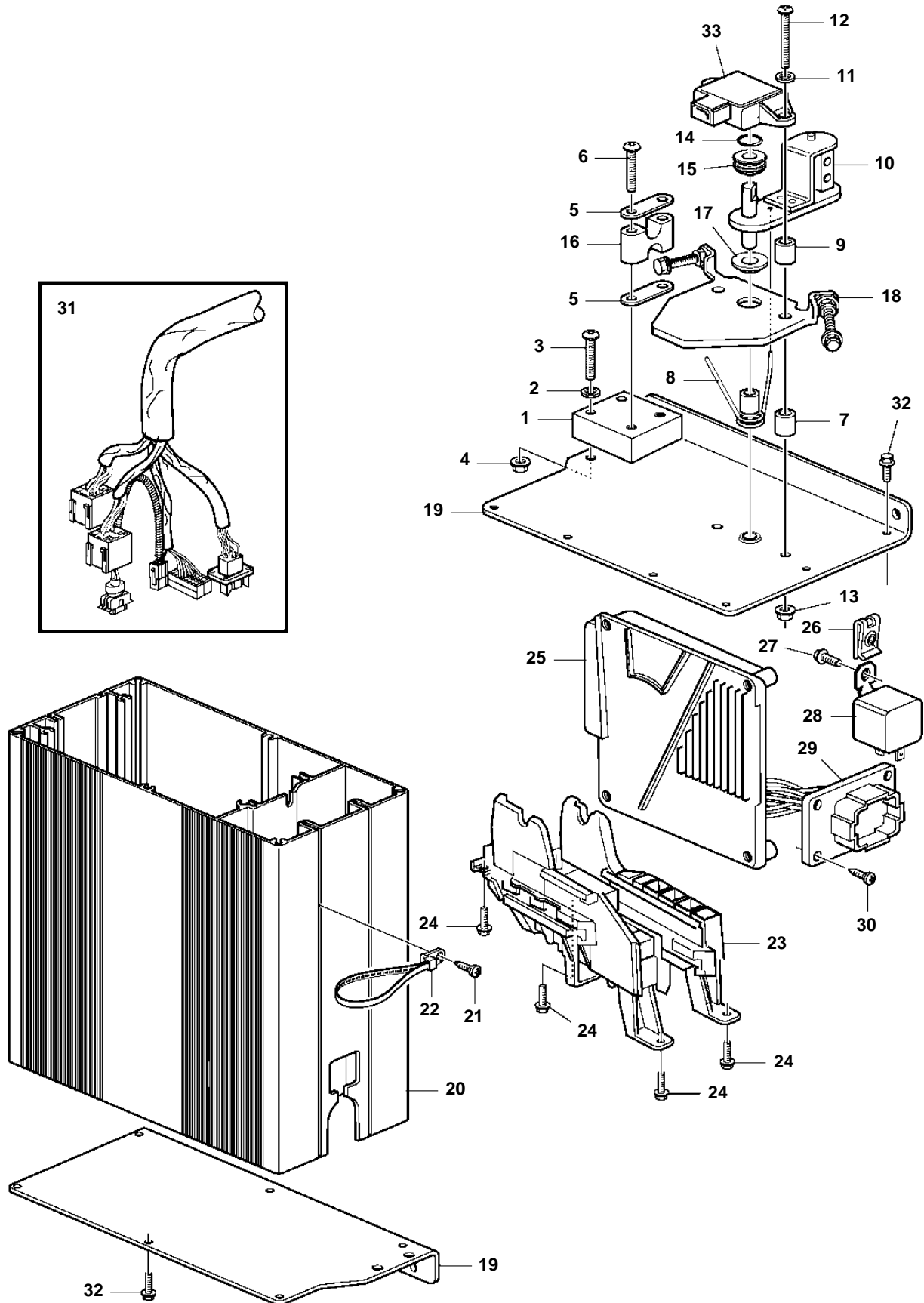

23639

D3-110I-A, D3-110I-B, D3-110I-C, D3-130A-A, D3-130I-A, D3-130A-B, D3-130I-B, D3-130A-C, D3-130I-C, D3-160A-A, D3-160I-A, D3-160A-B, D3-160I-B, D3-160A-C, D3-160I-C, D3-190A-B, D3-190I-B, D3-190A-C, D3-190I-C

REF	PART NO.	QTY	DESCRIPTION	NOTES
1	3819195	1	Bracket	
2	940090	2	Washer	
3	969439	2	6 point socket screw	
4	949874	2	Flange lock nut	
5	819068	2	Washer	
6	969439	2	6 point socket screw	
7	847150	3	Spacer sleeve	
8	3883921	1	Spring	
9		2	Spacer sleeve	
10	3812728	1	Intermediate lever	
11	940090	2	Washer	
12	969440	2	6 point socket screw	
13	949874	2	Flange lock nut	
14	943342	1	Sealing ring	
15	3829681	1	Washer	
16	872074	1	Retainer	
17	3829680	1	Bushing	
18	947542	2	Flange screw	
19	3807834	2	Cardboard tube	
20	3807556	1	Box frame	
21	969456	1	6 point socket screw	
22	949666	1	Cable tie	
23	3807843	1	Bracket	
24	947493	6	Flange screw	
25	3586930	1	Control unit	
	3586269		Software	Warehouse programming. This p/n can not be ordered, but will be used for invoicing.
	3586268		Software	Vodia-programming. This p/n can not be ordered, but will be used for invoicing.
26	191391	2	Spring nut	
27	947493	1	Flange screw	
28	873740	2	Relay	
29	3807365	1	Cable kit	
30	969456	4	6 point socket screw	
31	3807365	1	Cable kit	
32	947493	11	Flange screw	
33	1336385	1	Potentiometer	